





# PACKAGE CONTENTS

After receiving the product, please check whether it contains the following contents ① to ⑥.

① Main Device

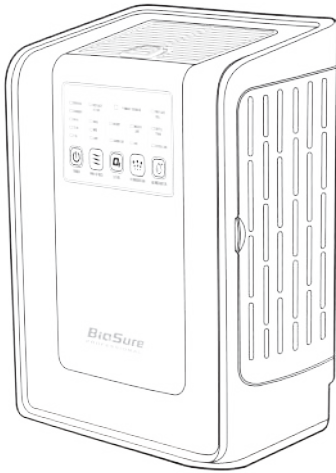

② Power Adapter

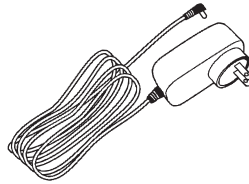

③ HEPA Filter

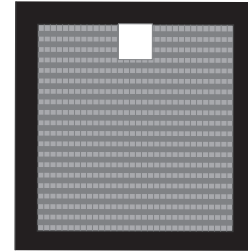

④ Wall Mount

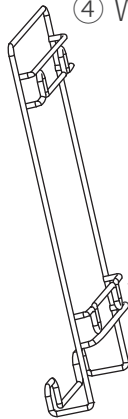

⑤ Hook Screws x 2

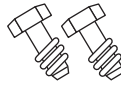

Expansion Screws x 2

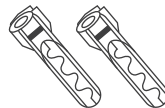

⑥ Product Manual



## 1. INTRODUCTION

Thank you for purchasing BioSure Space Sanitizer System Plus (Model: EOS7190-P). To ensure the correct use of the product, please read all safety warnings, precautions and instructions before use.

- Due to product upgrades, the appearance, specifications or content of the text are subject to change without notice.

**Disclaimer** (For more information about the warranty, please refer to the warranty document.)



This warranty may be invalid in the following cases:

1. Failure caused by improper installation, storage, or improper handling before the product is put into use.
2. Damage caused by unauthorized service organizations or unauthorized personnel trying to repair or install.
3. The labor costs derived from the normal maintenance, calibration, or general adjustment specified in this manual.
4. Maintenance or damage caused by alteration, abuse, fire, flood, or natural disasters.
5. Damage caused by failure to follow the instructions for maintenance or repair.
6. Removal, alteration, or damage to the serial number and/or label on the product will not be guaranteed.
7. Mechanical damage.
8. Damage caused by the use of water quality outside the product specifications.

*Please note, BES accepts no liability for misuse of its products. BES makes no warranty of any kind with respect to this information. BES SPECIFICALLY DISCLAIMS THE IMPLIED WARRANTY OF MERCHANTABILITY AND FITNESS FOR A PARTICULAR PURPOSE. Please consult local regulations and/or trusted professional when using ozone product for any application. BES shall not be liable for any direct, indirect, incidental, consequential, or other damage alleged in connection with the furnishing or use of this information.*

## 2.IMPORTANT SAFETY INSTRUCTIONS

To avoid personal injury or property damage to the user or others, please follow the following safety instructions :

 <b>WARNING</b>	WARNING indicates a dangerous situation, which may cause death or serious injury if not avoided.* <sup>1</sup>
 <b>CAUTION</b>	CAUTION indicates a dangerous situation that may cause personal injury* <sup>2</sup> or property damage* <sup>3</sup> if not avoided.

\*1 Serious injuries: blindness, injury, burns (high temperature / low temperature / chemicals), etc., will require hospitalization or long-term hospitalization.

\*2 Minor injuries: injuries, burns, electric shocks, etc., without hospitalization or long-term hospitalization.

\*3 Property damage: extensive damage to houses, household goods, pets, etc.

 Indicates "what you can't do" when operating the product.

 Indicates "what you must do" when operating the product.

### **WARNING**

- Do not use this product in places where there is no ventilation.
- Estimate the size of the room you want to use to plan the time setting for using this product.
- Misuse of this product may cause harm to people and pets.
- The continued accumulation of ozone may damage your property.
- Please use and store this product out of reach of children to avoid electric shock or injury.
- Please be careful when using in an environment with pets and plants.
- Please be aware that rusty items and natural rubber are prone to deterioration when exposed to ozone.
- If you feel uncomfortable with the smell of ozone, or feel any changes in your physical condition during use (for example, headache), please stop using, ventilate immediately, and consult your doctor.
- If you have a history of asthma, please consult your doctor before use.
- Do not place any objects in the area 0.8-1.5 m in front of the ozone outlet and no more than 0.5 m on the left and right sides.
- Please pay attention to ventilation when using it continuously for a long time in a closed room.
- Avoid blowing directly on pets and plants.
- When using this product in a room with a baby for a long time, please pay attention to ventilation and avoid blowing it directly on the baby.

### **WARNING**

#### **Special Exceptions/In Case Of Problem**

- **Stop using this product immediately and unplug it from the power outlet.**  
If the product emits smoke, peculiar smells, strange noises, or foreign objects enter the product, please stop using it immediately and disconnect the connection to the power adapter. In these events, continued use may cause fire, electric shock or personal injury.

#### **Main Device / Power Adapter**

- **Do not repair, modify or disassemble.**  
Failure to do so will invalidate your warranty and may result in fire or electric shock.

- **Avoid getting the device wet.**

Do not immerse the product in or splash water with water, as this may cause damage to the product or electric shock.

- **If the product is dropped and damaged, please stop using it immediately.**

Continued use may cause overheating, fire, electric shock, and injury.

- **Please use and store it out of the reach of children.**

Otherwise, it may cause electric shock or injury.

### **Main Device / Power Adapter**



- Do not place the device near heated or high temperature surfaces.  
Do not throw it into a fire or heat, as this may cause a fire, explosion or injury.
- Do not put this device in the refrigerator.  
This will be the cause of product failure.



- Do not plug or unplug the power cord when your hands are wet.  
Otherwise, it may cause electric shock or personal injury.

### **Main Device**



- Except for the dedicated power adapter, do not use other power sources.  
Using other power sources may cause overheating, fire, malfunction or injury.
- Do not throw water, soot, or flammable materials on the air outlet or air inlet.  
It may cause electric shock or fire.

### **Power Adapter**



- Please use the specified power supply voltage.  
Otherwise, it may cause electric shock, fire and damage the product. The input power of the power adapter of this product is AC100-240V.
- Do not use loose sockets.  
Otherwise, it may cause fire, electric shock or short circuit.
- Do not use a damaged power cord or power plug to operate the machine.  
Otherwise, it may cause electric shock or fire.



- Be sure to firmly insert the power adapter connection terminal into the power jack.  
If it is not fully inserted and used, it may cause electric shock or fire.

### **About installation and use**



- Do not use this product in places where there is no ventilation.
- Do not operate this product for a long time in a small room.
- Do not place any objects in the area 0.8-1.5 m in front of the air outlet and no more than 0.5 m on the left and right sides.  
Misuse of this product may cause injury to people or pets or damage to property.
- When installing the wall mount, please be careful not to let your fingers be caught by metal fittings.
- Make sure that the wall to be installed is strong enough.
- If the product falls during installation, it may cause damage to the product.
- Do not modify or change the installation parts, otherwise it may cause personal injury or property damage.



- This device is only suitable for indoor use, please do not use it outdoors.
- Avoid using it in places where it may be exposed to water.



### **Maintenance**

- When performing maintenance, be sure to turn off the power and disconnect the power adapter.  
Otherwise, it may cause electric shock or fire.



- Clean the dust on the power adapter regularly.  
Moisture can cause poor insulation and cause a fire.
- When not in use for a long time, be sure to disconnect the power adapter.  
If you do not use this product for a long time, please unplug the power.  
Otherwise, it may cause electric shock or fire.

## ATTENTION



- **Do not place it in a place exposed to direct sunlight or abnormally high temperature.**  
In addition to deteriorating the surface and parts of the equipment, it may also cause fire.  
Do not place it in a closed car, under direct sunlight or near heaters such as stoves.
- **Place the device on a flat and solid surface or on a solid wall.**  
Do not install the device in an unstable place, such as on a rocking table or inclined plane.  
It may fall and cause injury or product failure.
- **When moving or transporting, do not put the main device on its side.**



- **Use the correct water source.**  
This machine does not have a filtering function. Do not use well water or similar untreated water sources.
- **Please use pure water or distilled water (TDS <1ppm or EC <2 $\mu$ S/cm) for humidification.**
- **Make sure to use pure water or distilled water (TDS <1ppm or EC <2 $\mu$ S/cm) to generate ozone.**
- **Keep the inside of the humidification water tank clean and add pure water from time to time.**
- **If you do not use the product for 3 days or longer, please discard the water in the humidification water tank and empty the humidification water tank.**

### Maintenance



- **Do not use chemicals to clean.**  
Do not wipe the main device with gasoline, paint thinner, alcohol, etc. In addition, please do not use electrical (electronic contact) cleaners, in addition to damaging to the appearance these chemicals may also melt the parts.
- **Do not rinse the main device with water.**  
If the main unit is dirty, please clean it with a cloth soaked in neutral detergent or water, and then wipe it with a soft cloth.

# 3. INTRODUCTION OF MAIN COMPONENTS

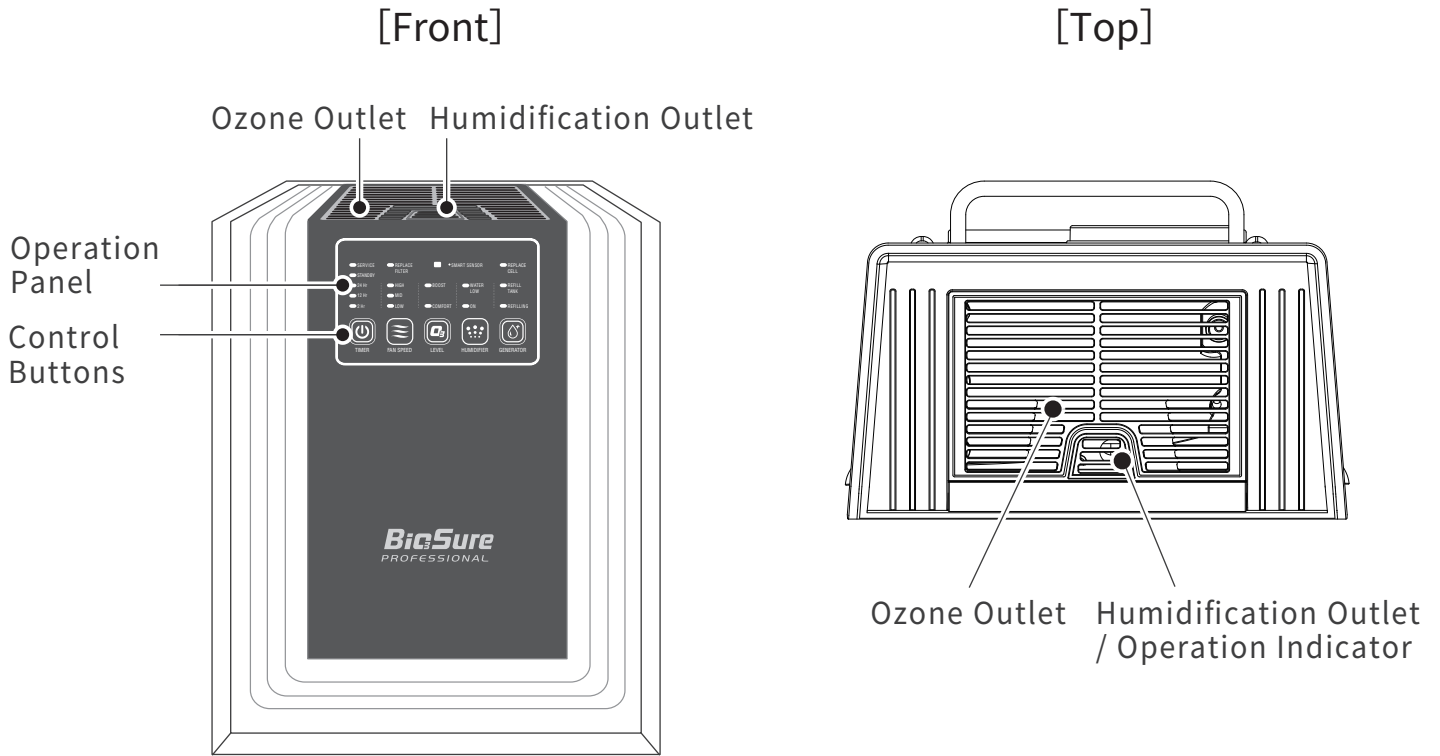

## Operation Panel

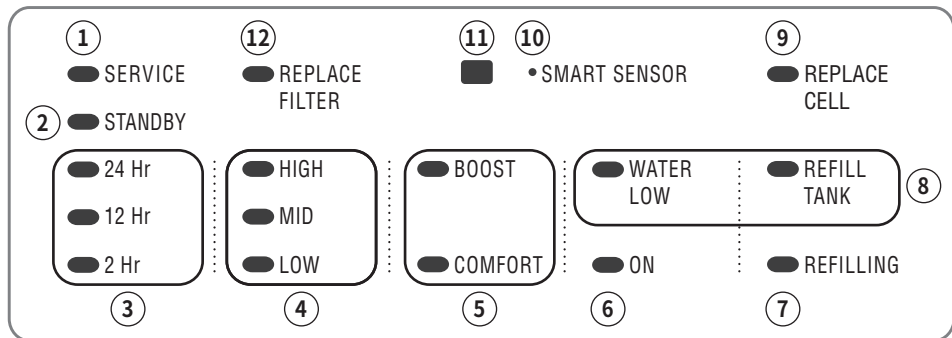

## Control Buttons

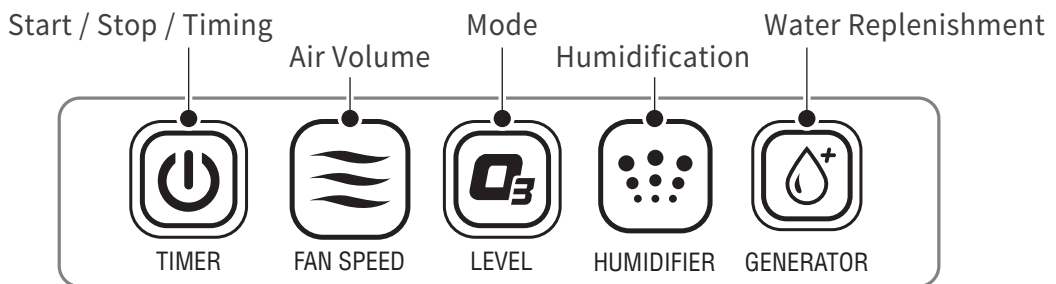

## Captions

- |   |  |                                     |
|---|--|-------------------------------------|
| ① Fault indicator   | ⑤ Mode indicator (boost/comfort)   | ⑨ Replace ozone generator indicator |
| ② Standby indicator   | ⑥ Humidifying indicator  | ⑩ Person(s) sensing indicator       |
| ③ Timing indicator (24/12/2 hours)<br>(In order from top to bottom)       | ⑦ Pure water tank replenishment indicator                                    | ⑪ Person(s) sensing device          |
| ④ Air volume indicator (high/medium/low)<br>(In order from top to bottom) | ⑧ Water shortage warning (humidify water/pure water)<br>(from left to right) | ⑫ Replace filter indicator          |

# 3. INTRODUCTION OF MAIN COMPONENTS

[Side] HEPA Filter side

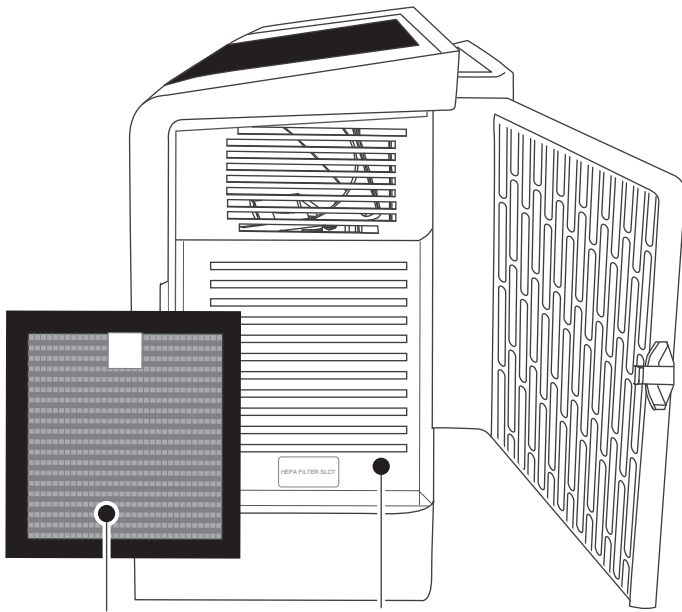

Accessories - HEPA filter  
HEPA filter slot

[Side] Humidification Water Tank side

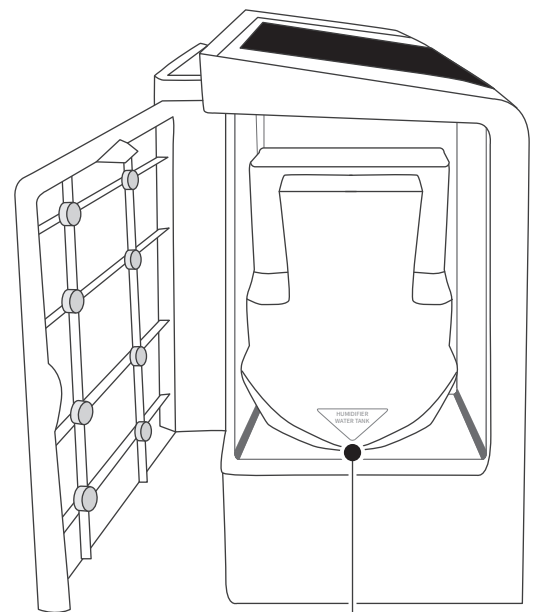

Humidification water tank

[Back]

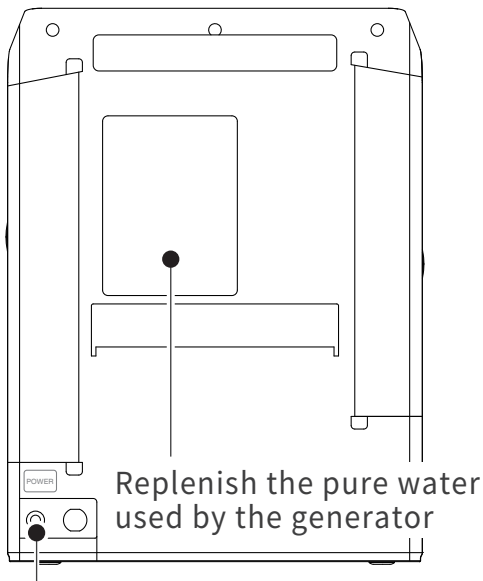

Power jack

Replenish the pure water used by the generator

[Bottom]

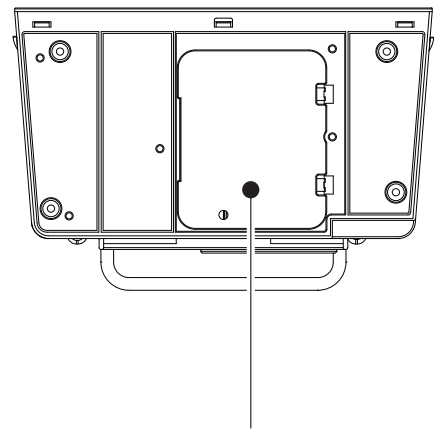

Drain the humidified water and pure water / replace the electrolytic ozone generator (EOG)

## Precautions for use

- Very low ozone concentration (0.01-0.02 ppm) can be sensed by human. The machine will give off a mild ozone smell it is normal and can be expected. If you feel negative physical conditions, any sudden changes, such as headaches during use, please stop using and ventilate immediately.
- To ensure your personal safety and avoid product damage, please read this manual carefully.

Ozone Concentration (ppm)	Affects
0.01 - 0.02	Olfactory perception of ozone odor
< 0.06	According to the Food and Drug Administration, FDA.
0.1	According the Occupational Safety and Health Administration, OSHA, the concentration standard for continuous exposure to ozone is limited to exposure for 8 hours.



## 4. PRODUCT FUNCTIONS AND FEATURES

You can choose different modes according to the conditions of use and environment.

※ For safety using, please hang the product on the wall or place it on a firm and flat table or shelf. When ozone is generated, the blue operation indicator on the top of the unit will be lit. This light cannot be turned off manually.

Disinfection and Deodorization  
with people in the room

**COMFORT MODE**  
(Used when person(s) is present)

Space Sterilization / Deodorization  
Humidification



Ozone controlled within a safe concentration range.

Perform low-concentration operations within a safe range to eliminate bacteria.

Disinfection and Deodorization after  
room personnel are cleared

**BOOST MODE**  
(Used when no person is present)

Space Sterilization / Deodorization  
Humidification



Higher concentration ozone.

Perform high-concentration air and space treatment. When the operation time expires, the ozone concentration will fall within the safety standard.



Only when there is no one present in the room, and no one will enter, may the Boost mode be used. Please evaluate for safety and only operate this mode during the time period when the room is not used.

※ If you enter the room and smell a strong ozone smell after the operation is stopped, please open the windows and doors for ventilation and leave the room immediately.

For safety in use, please hang the product on the wall or place it on a firm and flat table or shelf.

## 5. PREPARATION BEFORE USE

### ⚠ ATTENTION

When the product is turned on for the first time after purchase, the product will undergo a 30-minute preparation process. This is a standard protection procedure.

※ The final factory inspection of product production will use water for functional confirmation. We will dry it before transportation, but in some cases, water droplets may remain in the pipeline inside the main device.

- ① Take out the machine from the packing box, open the door on the left and take out the cushioning material that fixes the humidification water tank.
- ② Install the HEPA filter on the right side of the device.
- ③ Prepare 200ml-250ml pure water or distilled water. (TDS <1ppm or EC < 2μS/cm)
- ④ Insert the plug of the power adapter into the power jack.

Confirm the front  
back of the HEPA filter,  
correctly fit, and fix the  
filter.

The label is on the front  
and needs to face outwards.

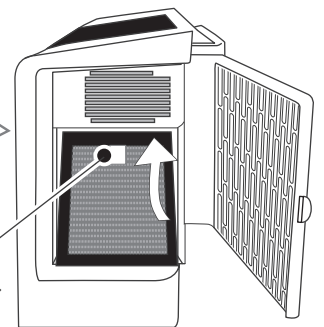

When the power is turned on for the first time, the WATER LOW, REFILL TANK, SMART SENSOR, STANDBY indicators will light up and the unit enters the standby state with one beep.

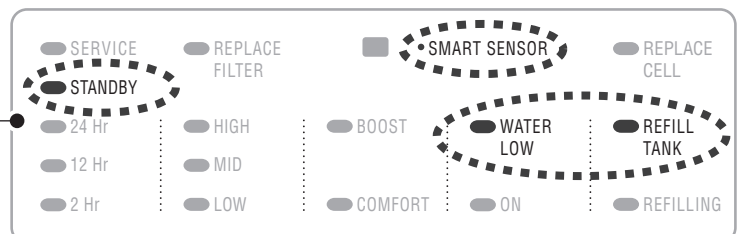

## 5. PREPARATION BEFORE USE

- 5** Supplement the pure water used in the EOG (Prepare 200-250ml of pure water or distilled water.)  
When the RIFILL TANK indicator lights up, it means that the electrolytic ozone generator (EOG) is short of water. At this time, the EOG stops working and needs to be supplemented with pure water before it can operate normally.

Open the back cover for replenishing pure water.

1. Remove the black plug at the bottom.
2. Remove the water shut-off valve.

3. Store the water shut-off valve on the storage clip.
4. Put the black plug back in place.

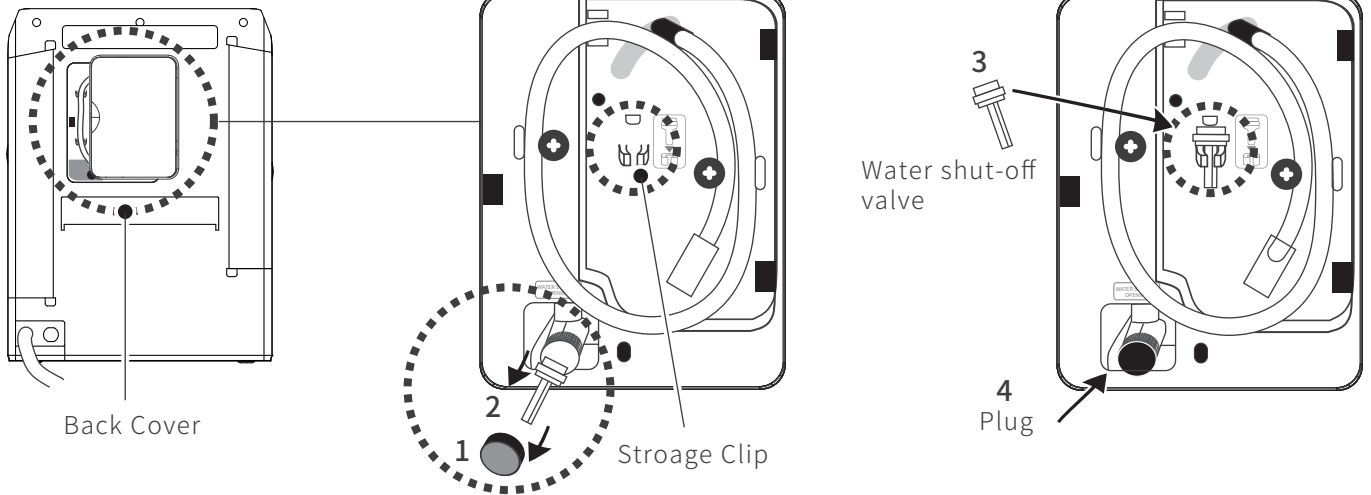

5. Take out the suction pipe, remove the pipe cap, and put the pipe into pure water bottle.

6. Press the "GENERATOR" button to start the water pump. The device will beep to start replenishing pure water. At this time, the REFILLING indicator will light up.

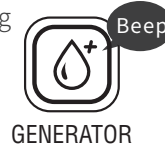

7. After the water replenishment is completed, the unit will beep again and the REFILL TANK indicator will go out.
8. Replace the suction pipe cap, return the pipe to its original position and close the back cover.

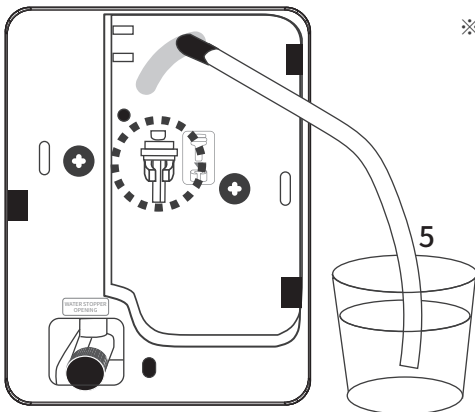

※ You can press and hold the GENERATOR key for 5 seconds in the standby mode to force the start of the water replenishment. The water pump will continue to operate until you release the button. If the water supply exceeds the pure water tank, water may overflow the unit. Please operate this function carefully.

Please use "pure water" or "distilled water". If you use this device for 8 hours a day, you need to refill it about once a month.



The water shut-off valve is stored on the storage clip. When transporting or moving the device, please reinstall the shut-off valve and remember to put the black plug back.

## 6 Replenish humidification water

Pour about 1200ml of pure water into the humidification water tank on the left. When the unit detects there is water in the water tank, the WATER LOW indicator goes out and the humidifying function can be used normally.

Please use pure water as humidification water. The humidification function needs to be replenished after about 8 hours of operation.

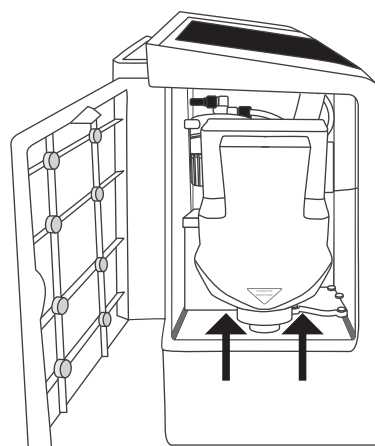

Lift up slightly to remove the water tank. Turn off the water tank cover to replenish water.

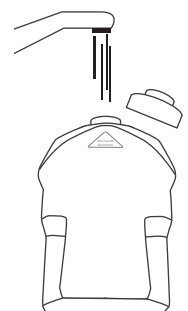

# 6.HOW TO USE

## COMFORT Mode

After pressing the TIMER button to start running, the system will first run with the default value of low air volume for 2 hours. At this time, the operation indicator on the top of the unit will be on.

You can change the air volume or timing setting at any time, please follow the figure below.

When the air volume is selected as 24Hr, the system will continue to operate until the pure water of the EOG is exhausted. In consideration of safety, the device sets the touch response time of the buttons to be slightly longer to prevent children from starting and operating easily. The timer will be recalculated when user adjust the setting during system operation.

Eliminate bacteria within a safe range concentration of ozone.

**!** The ozone concentration range of this mode is safe, but if you smell a strong ozone smell, please stop using it and open windows for ventilation.

## Stop Operation

During operation, keep pressing the TIMER button for 2 seconds, the system will beep ~ twice. The STANDBY indicator lights up and the device stops working.

## Humidification Function

If you need further humidification after starting the operation, please press HUMIDIFIER button.

**Stop humidification function**

Press the HUMIDIFIER button again and humidification function can be stopped.

- The humidification function cannot be performed alone.
- When humidification water is used up, the humidification function will stop, but the ozone generation will continue to operate.



**Activate the humidification function**

**Notification of Humidification Water Shortage**

If there is no water in the humidification water tank, the WATER LOW indicator will light up to inform you to add water.

Please refer to Sec. 5-6 for replenishing water for the humidification water tank.

## 6.HOW TO USE

### BOOST Mode

The unit will configure the air volume according to the time setting first, and user can change it later.

Boost is a more powerful mode for use only when no person(s) is present.

**Be sure to use the mode without anyone around.**

1. Press the TIMER key to start the unit, use the TIMER key to select the running time: 2 / 12 / or 24 hours continuous operation.



After selecting the running time, the unit will automatically configure the air volume. User can adjust it by FAN SPEED key. Check the table on the right for reference.

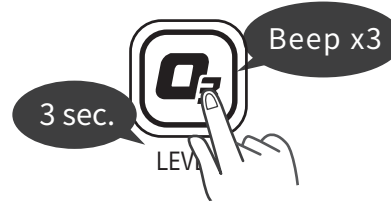

Air Volume (FAN SPEED)	Space Area	
	m <sup>2</sup>	ft <sup>2</sup>
L	150	1600
M	100	1060
S	50	530

\*The max area of recommendation

2. Press and hold the LEVEL button for at least 3 seconds to activate the Boost mode.
3. The device emits 3 beeps, the BOOST indicator will light up and start to run in the Boost mode.

When you activate the Boost mode, please leave the room immediately. For safety reasons, the smart sensor will be triggered and stop the unit automatically if you enter the room. To restart, press the TIMER key.

※ You can press the LEVEL button again to return to the comfort mode.

4. If you choose the Boost mode, for safety reasons, the device will beep every 10 minutes.

This warning sound cannot be cancelled.

5. The unit produces ozone in the first half of each cycle during operation, and air circulation in the second half. When the time expires, the ozone concentration will fall within the safety standard.

At the end of the operation time, the ozone concentration will drop to the safe allowable range, but if you feel a strong ozone smell when you enter the room, please open the window for ventilation.

※ Switch the setting during system operation, the running time will be recalculated.



Be sure to confirm that there is no one in the room, and choose the operating time carefully to prevent someone from entering by mistake.

### SMART SENSOR

Person(s) sensing function (SMART SENSOR) will be activated 5 minutes after the device starts to operate. If the unit senses a person's movement during operation, the red indicator on the panel will change from steady light on to slow flashing, the unit stops running, and the STANDBY indicator turns on. To start again, press the TIMER key.

※ When the system is in standby (the ozone function is not running), the SMART SENSOR function sleeps.

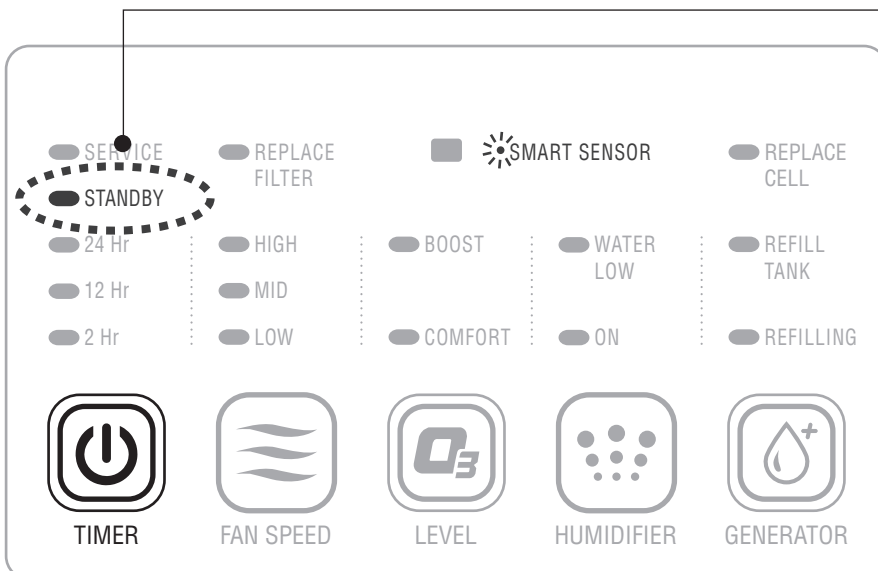

Restart the system



Press again TIMER button

Turn off the SMART SENSOR

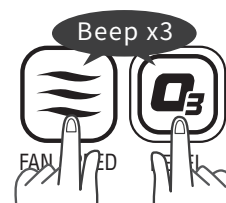

Press and hold the FAN SPEED and LEVEL buttons for 3 sec.. The SMART SENSOR is turned off when you hear three beeps. The SMART SENSOR indicator goes out in the mean time.

※ By default, the SMART SENSOR function in Comfort mode is turned off and turned on in Boost mode.

## 7-①.MAINTENANCE - Replace DI water filter / HEPA filter



When the REPLACE FILTER indicator lights up, stop the operation and replace the DI water filter and HEPA filter at the same time.

※ Please make sure to replace the DI water filter and HEPA filter at the same time.

※ For purchasing consumables and related inquiries, please contact your BioSure distributor.

### ■ Replace the DI water filter

A mandatory for maintaining the unit performance.

It must be replaced regularly to maintain the performance of the equipment.

When the indicator light is on, please stop using the device and replace the filter immediately.

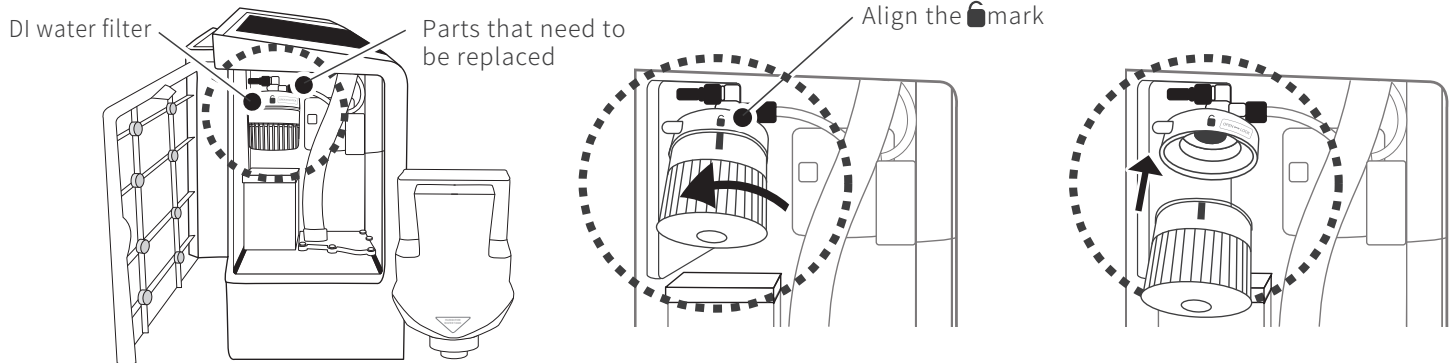

1. Lift and remove the humidification water tank. Replace the DI water filter at the back.

2. Tilt the filter slightly outward. Anticlockwise rotation filter to the straight line mark on the filter bottle align with the  mark on the top, and then remove the filter element.

3. Align the upper and lower marks to install the new filter.

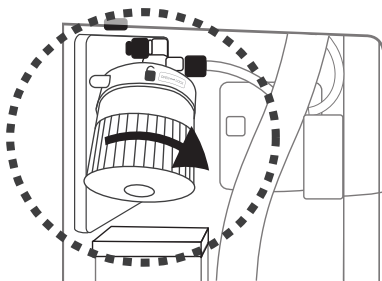

4. Rotate clockwise to the right.

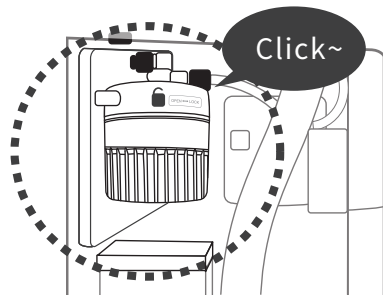

5. When you restore the filter to its original position, you will hear a click.

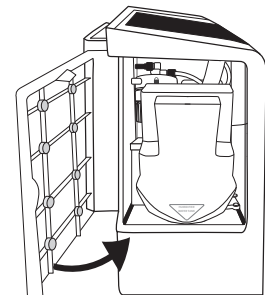

6. Replace the water tank and close the side panel.

### ■ Replace the HEPA filter

A mandatory for maintaining the unit performance.

When the indicator lights up, stop using the device and replace the HEPA filter immediately. Open the side panel and pull out the filter, replace with a new HEPA filter.



After replacing the "DI water filter" and the "HEPA filter", you need to reset the timer.

Make sure the unit is powered on.  
Press and hold the LEVEL key for 10 sec till the unit beeps and the "REPLACE FILTER" flashes 6 times.  
The timer reset operation has been completed when you see the REPLACE FILTER indicator lights off.



The label on the top of the HEPA filter is the outer side.

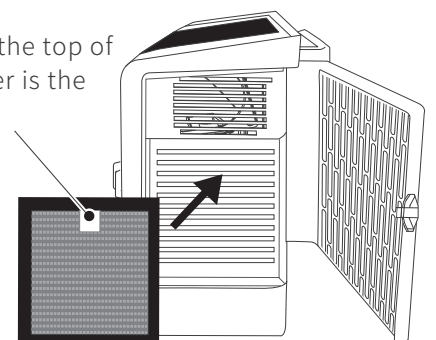

## 7-②.MAINTENANCE - Draining of humidified water and pure water

- ⚠ When cleaning the machine by draining humidified water and pure water, be sure to stop the operation and disconnect the power.



### ■ Main Device Body

Use a cloth dipped in neutral detergent or water to clean the main device, the top air outlet and the sides, and then wipe it with a soft dry cloth. Do not use alcohol or thinner.

### ■ The air outlet can be disassembled

- ⚠ During transportation, long-term non-use and replacement of the EOG, the humidification water and the pure water used by the EOG must be drained.

※ The discharge points of pure water and humidified water are different, please refer to the figure below when you discharge the operation.

### ■ Discharge the humidification water and the pure water of the EOG

- ⚠ If the main device is turned upside down, it may leak water and cause malfunctions.

1. Stop the operation of the equipment and remove the humidification water tank. Press down the two tabs at the bottom, and then remove the bottom cover.

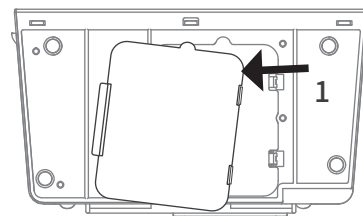

### ■ Drain humidification water

2. Be sure to remove the humidification water tank before draining water. Remove the silicone cover. Please prepare a container in advance. The humidifying water will be drained immediately after removing the silicone cover.

4. Reinstall the bottom cover: Hook the bottom cover hook to the main device, then close the two tabs and replace the bottom cover.

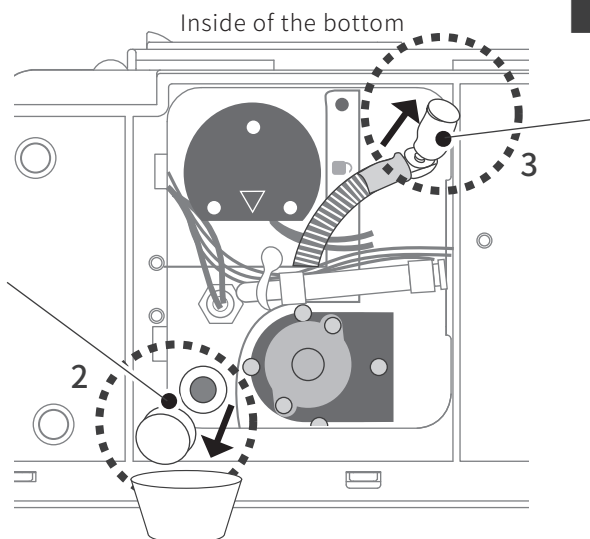

### ■ Drain pure water

3. Remove the cover to drain water.



The pure water will be discharged immediately after removing the cap. Please prepare a container in advance.

※ During transportation, long-term non-use and replacement of the electrolytic ozone generator, the humidification water and the pure water used by the electrolytic ozone generator must be drained.

### Protection of the EOG after draining the pure water

After the pure water is drained, remove the back cover of the main device.

1. Remove the black plug at the bottom left of the back cover of the main device, and use a dropper to inject about 20ml of pure water.
2. Insert the water shutoff valve.
3. Replace the black plug, and then replace the back cover.

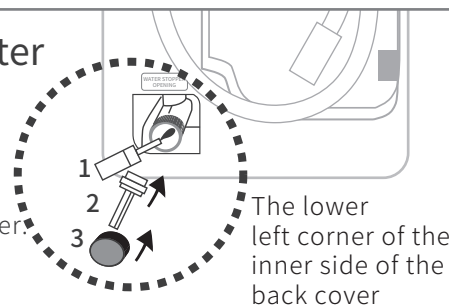

## 7-③.MAINTENANCE -Install Wall Mount / EOG

### Replace the EOG

When the electrolytic ozone generator (EOG) reaches its end of life, the REPLACE CELL Indicator will light up. Please stop the unit and replace it.

※ The service life of the electrolytic ozone generator is about 9,000 hours. The actual time depends on how often the device is used.

※ For purchasing consumables and related inquiries, please contact your BioSure distributor.

When REPLACE CELL indicator lights on, please perform replacement

Replace the EOG

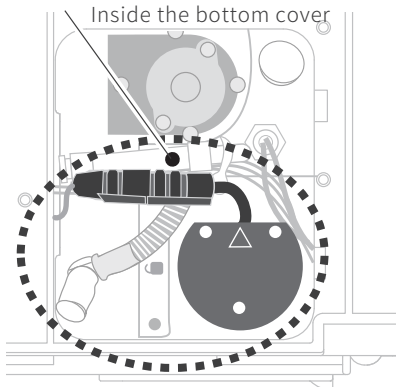

1. Press down the two tabs at the bottom, and then remove the bottom cover.

Connection terminal

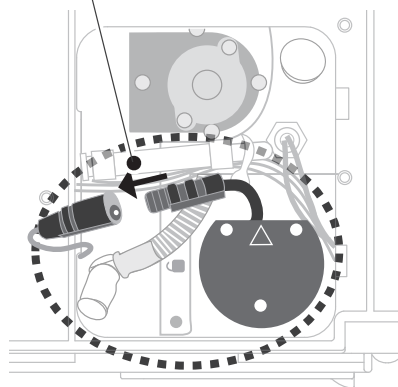

2. Separate the terminals of EOG and the main unit.

Mark

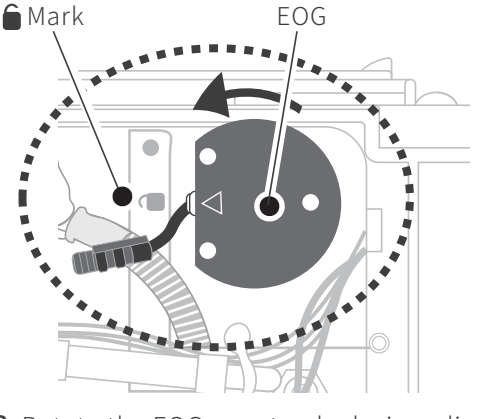

3. Rotate the EOG counterclockwise, align the  $\triangle$  mark on the EOG with the  $\mathbb{L}$  mark on the unit, and then pull the EOG up to remove it.

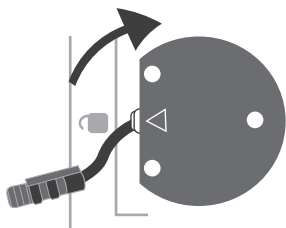

4. Install a new EOG. Align the  $\triangle$  mark on the EOG with the  $\mathbb{L}$  mark on the main unit. Turn the EOG tight clockwise.

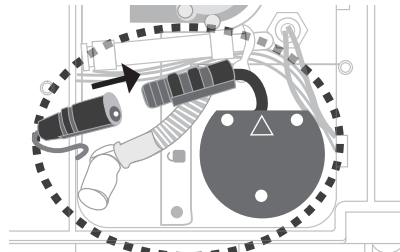

5. Connect the terminals.



After replacing the EOG, a system reset is required.

Keep the power supply on. Press and hold the LEVEL key for 20 seconds, the REPLACE FILTER indicator will flash once. Keep on pressing it and the indicator will flash 6 times. The REPLACE CELL indicator turns off when reset is complete.



6. Replace the bottom cover:

Hook the bottom cover hook to the main device, then close the two tabs and replace the bottom cover.

※When replacing the EOG, please replace the "DI water filter" and the "HEPA filter" at the same time.

### Install Wall Mount

### Affixing unit to wall



1. Drill two holes with a diameter of 6 mm and a center distance of 6 cm in the wall.

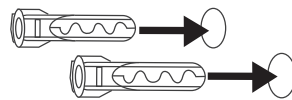

2. Hammer the expansion screws into the holes.

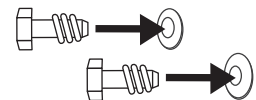

3. Lock the hook screws into the expansion screws.

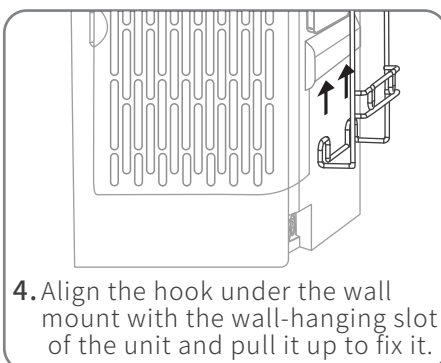

4. Align the hook under the wall mount with the wall-hanging slot of the unit and pull it up to fix it.

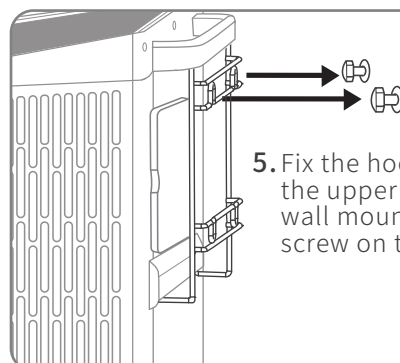

5. Fix the hook holes at the upper end of the wall mount to the screw on the wall.

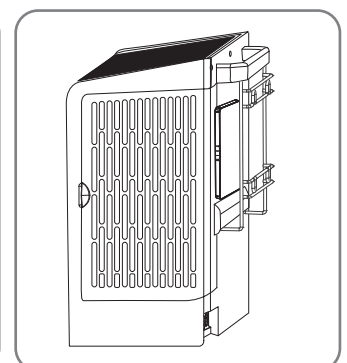

## 8.TROUBLESHOOTING

Use the following guide to self-check your problems before requesting repairs.If you come into a conclusion that problem has occurred, do NOT attempt to disassemble and repair the product yourself, but contact BioSure or your dealer for support.

**Sometimes suspected problem is remedied by disconnecting the power plug and then re-connecting it.**

Symptom	Possible Cause	Recommended Solution
Device doesn't work.	Power is not connected.	Use the power adapter attached in the product package.
		Make sure the terminal of the power adapter is inserted into the power jack of the device.
Water Leaking.	The unit is tilt.	If the main device is placed at an angle, the humidification water may leak out.
Control button(s) doesn't work.	Did not touch the center of the operation button.	Accurately touch the center of the operation button.
The REPLACE FILTER indicator lights up.	The life of DI water filter and HEPA filter have expired.	Please follow the instructions in section 7-1 to replace the DI water filter and HEPA filter.
The REPLACE CELL indicator lights up.	The life of the EOG has expired.	Please follow the instructions in section 7-3 to replace the EOG.
The WATER LOW indicator lights up.	Insufficient of humidification water.	Replenish pure water to the humidification water tank according to the instructions in section 5-6. Water quality: TDS <1ppm or EC <2μS/cm
The REFILL TANK indicator lights up.	Insufficient pure water for the EOG.	Replenish pure water or distilled water in accordance with the instructions in Section 5-5. If the indicator warning still cannot be removed, please contact your service agent.
The REFILL TANK indicator blinks.	When replenishing the pure water for the EOG, the user stops replenishing before the tank is filled.	The system can work normally. If you want to turn off the light, please power it up again.
I smell a strange smell at the ozone outlet.	This is the smell of ozone.	The design of this product has fully considered safety, but some people may still feel a strong smell.
The SERVICE indicator lights up.	The EOG fails. The unit stops running.	Please contact your service agent.

※ If the above solutions do not solve the problems, please contact BioSure distributor.



## 9. SPECIFICATIONS

Product Name		Space Sanitizer System Plus
Model		EOS7190-P
Water Supply for Humidification		Pure water or distilled water (TDS < 1ppm or EC < 2μS/cm)
Water Supply for the EOG		Pure water or distilled water (TDS < 1ppm or EC < 2μS/cm)
Power		AC 100 - 240V, 50 - 60Hz, 33W
Ambient Temp		Room temperature 5 - 35°C
Dimensions and Weight	Dimensions	W230 x D127 x H300(mm)
	Location Requirements	For use on a hard, level, and stable surface or wall mount only
	Weight	2.5kg (Unfilled)

### 【Waste Disposal】

When disposing of this product, follow the instructions of the local government (local regulations) for disposal.

【Consumable Parts】 The models of consumables are as follows.

C12011000303-80	Electrolytic Ozone Generator (EOG)
A71902007041	HEPA Filter
B71902007010	DI Water Filter

※ For purchasing consumables and related inquiries, please contact your BioSure distributor.

## WARRANTY DESCRIPTION

BioSure Professional is a division of Biotek Environmental Science Ltd. (BES). BES is a global leading electrolytic product manufacturer with pioneering ozone application technology and currently holds many exclusive patents for its electrolytic ozone generators and products worldwide.

Equipment manufactured by Biotek Environmental Science Ltd. has been constructed of the finest materials available and manufactured to high quality standards. When installed in accordance with manufacturer's recommendations, and under normal use and service, new BioSure products are warranted to be free of defects due to poor materials or workmanship for the period of time listed below (following the date of purchase):

- Main Device :

2 Years Parts Only Replacement (excluding wear and consumable parts)

- Consumable Parts :

1. Electrolytic ozone generator - within the hour usage life-span monitored by the unit, or 1 year from the date of installation, the date of installation, whichever comes first. Parts only. The limited warranty of BES only covers ozone generators that fail due to manufacturing defects, but not those are depleted due to normal use.
2. DI water filter & HEPA filter - Except for goods due to manufacturing defects or poor quality, it's not guaranteed or returned after unpacking or use.

If the product fails during the warranty period, please show your proof of purchase to your dealer and ask for repairs. If the product is not in the place of purchase for on-site maintenance or the product needs to be shipped, the actual costs incurred, such as transportation fees, may be charged.

Exclusions: Certain BES parts that are expendable by nature and that need to be replaced frequently may not be covered. BES is not liable under these warranties for repairs or damages due to improper operation, attempted repairs or installation by unauthorized persons, alterations, abuse, fire, flood, or acts of nature. Additionally, this warranty may be voided in the case of:

- Failure to follow BES (and BioSure Professional) instructions for use, care, or maintenance
- Removal, alteration, or defacing of the BES-affixed serial number and other labels
- Mechanical damage
- Use of fluids other than clean, potable water

This warranty is conditional upon BES receiving notice of any defect subject to this warranty within thirty (30) days of its original discovery by the Buyer. For service or warranty questions, contact the BES service department or BES authorized dealer nearby.





***BioSure***  
***PROFESSIONAL***

BES Group / Biotek Environmental Science Ltd.

[info@besgroups.com](mailto:info@besgroups.com)

[www.besgroups.com](http://www.besgroups.com)